

TIFFIN'S ROLL LOADER CRANE PUTS MORE VERSATILITY IN MATERIAL HANDLING

TIFFIN PALFINGER



THE ONLY RETAIL FACILITY OF ITS KIND IN NORTH AMERICA

THE BETTER SOLUTION FOR YOUR MATERIAL HANDLING NEEDS

PALFINGER IS A WORLD LEADER IN THE DESIGN AND MANUFACTURING OF INDUSTRIAL MATERIAL HANDLING PRODUCTS. OUR POOL OF DEDICATED ENGINEERS ARE SPECIALISTS IN CRANE, FORKLIFT AND HOOKLIFT APPLICATIONS AND DESIGN.

TIFFIN LOADER CRANE IS PALFINGER'S FLAGSHIP RETAIL AND FABRICATING FACILITY RESPONSIBLE FOR THE DEVELOPMENT OF SPECIALTY MATERIAL PRODUCTS INCLUDING TIFFIN'S ROLLING BASE CRANES.

The traveling unloader light-weight delivery system is designed for maximum payload and superior performance and for economical delivery of a variety of building and industrial products. PALFINGER/TLC offers a wide range of traveling unloaders, the most popular models handling 3,000 to 5,000 pounds. For requirements over 5,000 pounds, contact your Tiffin representative.

Our fabricators can easily adapt standard trailers for use with a PALFINGER /TLC traveling unloader. Each trailer is provided with extra heavy duty undercarriage to withstand the maximum torque at full load.

A rolling base crane can easily be transferred from one flatbed to another.

ADVANTAGES:

- Long reach to pick, sort or retrieve materials among multiple rows
- The crane can be stored almost anywhere on the trailer allowing flexibility of transporting, loading and unloading of materials or products
- Quick cycle times due to return oil utilization on the crane
- Light-weight for maximum payload
- Low overall height

FEATURES:

- Crane only occupies 48" of deck space (PK 9501)
- All functions can be operated from ground level using the available remote control
- Manual or hydraulic outriggers for stabilization
- Drive chains run inside the undercarriage to provide greater protection for the operator

- The undercarriage has large, 7-inch wheels that allows smooth running of the unloader
- Axle bushings can be easily changed without cutting torches
- Ease of access to engine, pump, valve and hoses
- Crane engine can be equipped as gasoline or diesel
- Grippers that ride under the trailer rail are adjustable and easily replaceable
- Large diameter axles eliminate premature wear
- All moveable parts have grease fittings and replaceable bushings
- Additional hydraulic attachments at boom tip are available





The PALFINGER crane travels the full length of the flatbed

APPLICATIONS:

- Bagged products
- Brick, block & pavers
- Building materials:
 - Drywall
 - Lumber
 - Masonry
 - Pipe
 - Roofing
- Chlorine & propane tanks
- Landscaping
- Monuments
- Pre-cast concrete
- Railway
- Transformers
- Specialty in-plant and industrial applications



Crane only occupies
48" of deck space

48"

PALFINGER/TIFFIN ROLL LOADER LOAD CHARTS



We service what we sell

Averting problems before they start – avoid major breakdowns, extend the life of your equipment, and keep downtime to a minimum by investing in a comprehensive service contract.

This annual service applies to all single unit or fleet customers.

MOBILE SERVICE

TIFFIN'S service technicians can provide complete field inspection with their fully equipped service vehicles including:

- Computerized diagnostic
- Inspection of all electrical, mechanical and hydraulic components
- Fully equipped trucks to handle most on-site repairs
- Factory trained technicians
- Factory replacement parts



PK 7501

LIFT CAPACITY DIAGRAMS

PK 7501A

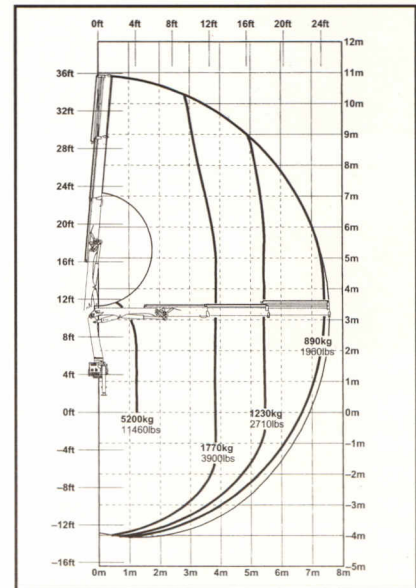
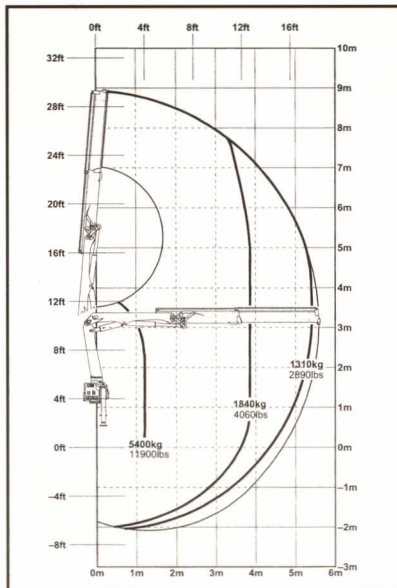

PK 9501

LIFT CAPACITY DIAGRAMS

PK 9501A

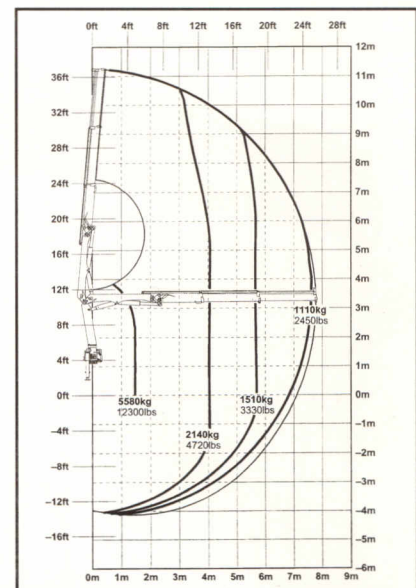
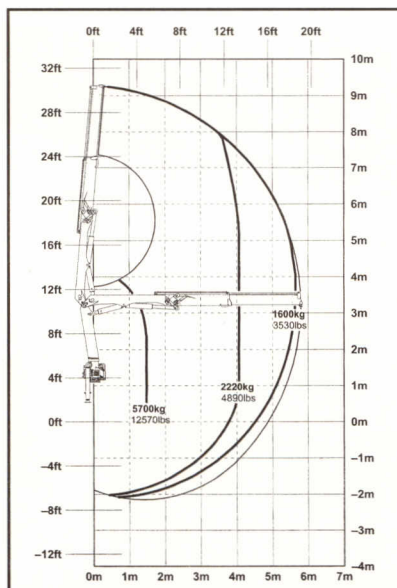

Contact TIFFIN Loader Crane for additional models and configurations

PALFINGER PRODUCTS INCLUDE...

Truck Mounted Cranes

Service Cranes

Crayler Forklifts

Palift Hook Loaders



TIFFIN LOADER CRANE CO.
4151 West State Route 18
Tiffin, OH 44883

Tel: 419 448-8156
Fax: 419 448-9558
E-mail: frontdesk@tiffincrane.com